

Mamibot

Ultra Robot Window Cleaner

iGLASSBOT W120-DP

Featured with Four Self-Water-Spray Nozzles

EN

USER MANUAL

V.20241224.

Thanks for purchasing Mamibot Robot Window cleaner W120-DP featured with four self-water-spray hole type.

We hope W120-DP will bring you a smarter and more convenient lifestyle.

If you encounter any problem not mentioned herein, please contact info@mamibot.com.

For more details, please visit our official website:
<http://www.mamibot.com>.

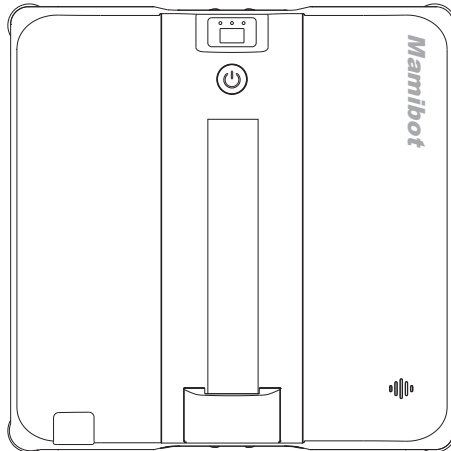

Please read all instructions before using this product, and keep it properly for future reference.

Table of Contents

2-3	Safety Instructions and Warning
4	Specification
5	What's in the package
6-7	Product Description Main Unit Remote
8-10	Function Menu
10	Indicator Introduction & Abnormity
11-12	Installation Charging Cleaning cloth installtion Fill Up the Water Tank Safety Rope Fixing
12-13	To Use W120-DP
14-15	App Use
16	Maintenance
17	Product Warranty
17-19	Questions & Answers
19	Troubleshooting
20	Correct Disposal & Conformity

Safety Instructions and Warning

Please read all instructions carefully, and keep it at hand for setting up, using and maintaining W120-DP. Any operation that against the following instruction may damage the device or cause injury.

W120-DP is not to be used by children. Persons with reduced physical, sensory or mental capabilities, or lack of experience and knowledge may only use this device if they are supervised or have been given instruction about how to use it safely and understand what risks are involved.

Notes for Main Unit and Components

- ▲ Use only the original adapter, plug and battery. Use of other types will result in malfunction and / or danger.
- ▲ Use the proper electric outlet and make sure no heavy objects are placed on the adapter or power cord.
- ▲ Allow adequate ventilation around the adapter when using it to operate the device. Do not cover the adapter with objects that will reduce cooling.
- ▲ Always switch W120-DP off before carrying out any cleaning or maintenance work.
- ▲ Do not use W120-DP in a high moisture environment. Never handle the adapter with wet hands.
- ▲ Connect the adapter to a proper power source. The voltage requirements can be found on the adapter.
- ▲ Do not use broken adapter, power cord or plug. The plug must be removed from the outlet before cleaning or remaining the device. Do not unplug the plug by pulling the power cord.
- ▲ Do not attempt to service the adapter and battery. Replace the whole unit if it is damaged or exposed to high moisture. Contact Mamibot dealer for help and maintenance.
- ▲ The battery used in this device may present a risk of fire or chemical burn if mistreated. Do not disassemble, short circuit, heat above 40°C (104°F), or incinerate.
- ▲ Do not expose your W120-DP, adapter and battery to rain or excess humidity, and keep it away from liquids (such as beverages, faucets, and so on).
- ▲ Avoid exposing your W120-DP, adapter to direct sunlight or intense light source, and keep it away from heat source (such as radiators, space heater, stoves and so on).
- ▲ Do not place your W120-DP in the vicinity of strong magnetic fields.
- ▲ Do not use it on cracked glass or to clean other surface with uneven area as it may fall off due to insufficient suction power.
- ▲ Operating W120-DP at temperature: 0°C-40°C (32°F-104°F)
- ▲ W120-DP must be used in accordance with the instruction manual.

▲ Manufacturer can not take any responsibilities for any damages or injuries caused by improper use.

Warning

- ▲ Check if the safety rope and extension cable are broken or not before use.
- ▲ Fasten the safety rope and tie it to indoor fixtures before using W120-DP.
- ▲ Set danger warning area downstairs for no-balcony window and door.
- ▲ Battery shall be charged (Green light is on on the robot) before use.
- ▲ Do not use it on rainy or moist days.
- ▲ Switch power on before you put device onto glass.
- ▲ Make sure W120-DP can stick and stand on glass surface while put onto glass.
- ▲ Make sure to put the cleaning pad on the bottom of W120-DP correctly to avoid water leakage.
- ▲ Do not spray or pour water onto W120-DP and adapter.
- ▲ Keep hair, loose clothing, fingers and all parts of body away from the openings and moving parts.
- ▲ Do not use in areas with existed flammable or combustible liquids, gas.
- ▲ Please fully charge (about 2 hrs) and turn off W120-DP and place it in a cool and dry place if you do not use it for a long time. Charge it every 3 months at least to avoid battery dead.
- ▲ Please turn the switch on when you are going to use W120-DP, so that you can check the status of indicator.

Note:

- 1.W120-DP is not a cordless cleaner, it can only work properly when connects to the adapter and power source.
- 2.W120-DP should be charged fully at initial use: an UPS (Uninterrupted Power Supply) system is embeded in the device. When UPS is fully charged, it supports W120-DP to stay on the working surface for 20-30 minutes if there is a sudden power outage.

Specification

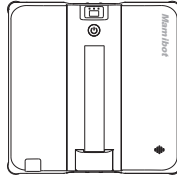

Product Model	W120-DP
Size of Main Unit	229*229*69 mm
Net Weight	About 1.45KG
Adapter Input	100-240VAC ~ 50/60Hz
Adapter Output	24.0V \equiv 3.00A
Rated Wattage	72W
Battery Type	Rechargeable Li-ion Battery
Battery Capacity	500mAh
Robot Rated Voltage	24V \equiv
Charging Time	About 2 hours
The Min. workable Surface	60 x 40 cm
Water Tank Capacity	About 60 ml
Working Noise	< 75dB
Spraying Drive Type	Motor-Driven Water Spray
<p>※ The datas come from the lab of Mamibot Manufacturing USA Inc. It may be slightly different from the users' data, please subject to the actual products. For continous products improvement, we reserve the right to any technical and design change without prior notice.</p>	

What's in the package

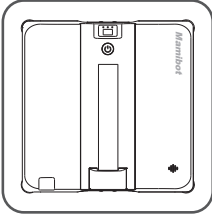

W120-DP x 1pc
with Safety Rope

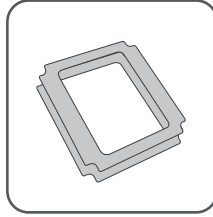

Cleaning cloth x 2 pcs

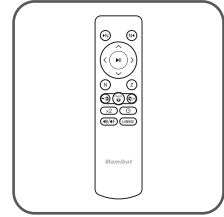

Remote x 1pcs

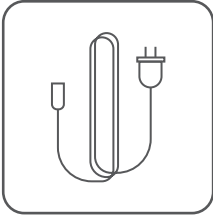

AC Plug x 1pcs
(with power cord)

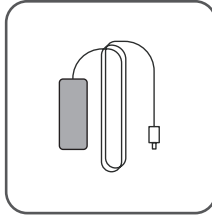

Adapter x 1pcs

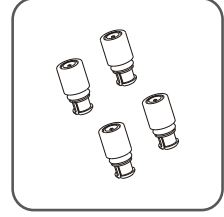

Spray nozzle x 4 pcs

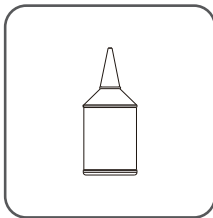

Measuring Cup x 1pcs



Unclogging Needle Kit x 1set



User Manual x 1pcs

Accessories of some models may be slightly different and they are subject to the actual received products.

Product Description

Main Unit

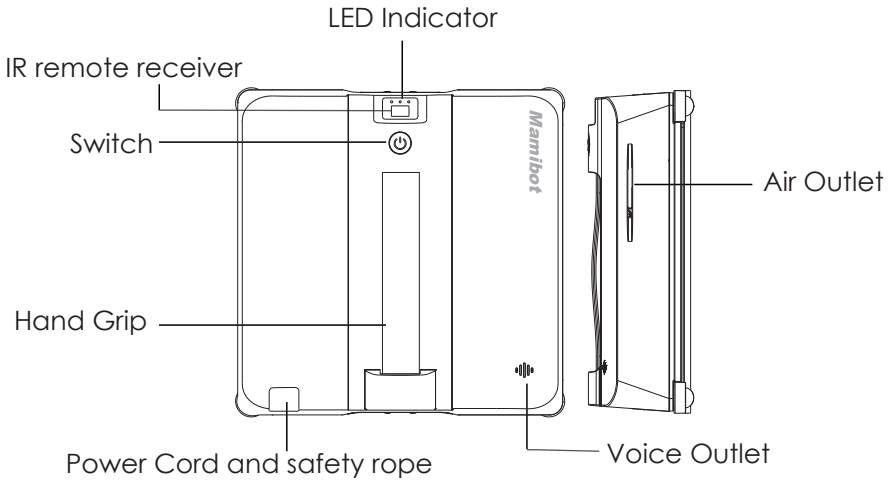

Top + Side View

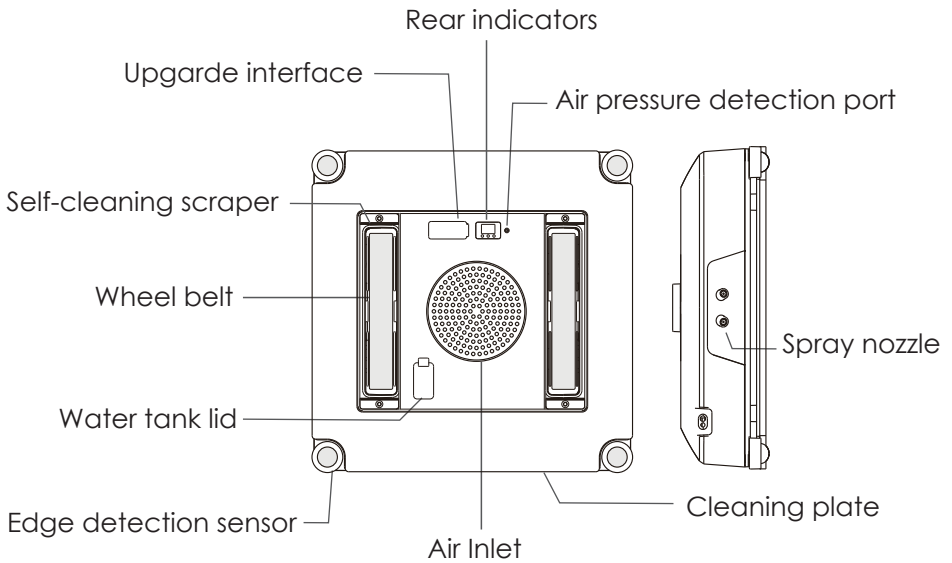

Bottom + Side View

Remote instruction



	Cleaning the left area in N-Type
	Cleaning the right area in N-Type
	Cleaning upwards button
	Cleaning downwards button
	Cleaning leftwards button
	Cleaning rightwards button
	Cleaning starts / pause button
	Auto N-Type cleaning button
	Auto Z-Type cleaning button
	Regular spray button
	Strong spray button
	Water spray on / off button
	Deep cleaning button
	Spot cleaning button
	Voice on / off button
	Language settings button

Remote Control

Notice:

1. Please place 2 x AAA battery into the remote before use. Make sure that the positive and negative are not reversed to avoid short circuit or injuries.
2. In order to prevent misuse, please pause the device first before using other commands, otherwise, the commands will be invalid.

Function Menu

※ Please make sure the edge of W120-DP is 8cm or more away from window frames or corners before cleaning (as Fig.B on Page 13).

Z N-Type cleaning mode

Start W120-DP in the center of the glass. It will detect the frame upwards first, and the frame left second, after that, it will start cleaning with Z shaped path.

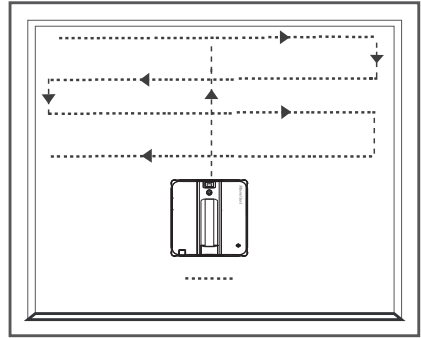

"Z" Shaped Path

N-Type cleaning mode

Start W120-DP in the center of the glass. It will detect the frame upwards first, and the frame left second, after that, it start cleaning with N shaped path.

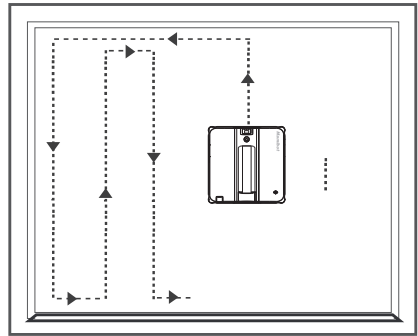

"N" Shaped Path

x 2 Deep cleaning mode

Press the button on remote or App, W120-DP will clean the glass with "Z" & "N" shaped path.

Spot cleaning mode

Press the button on remote or App, W120-DP will perform up and down, left and right reciprocating cleaning four times respectively.

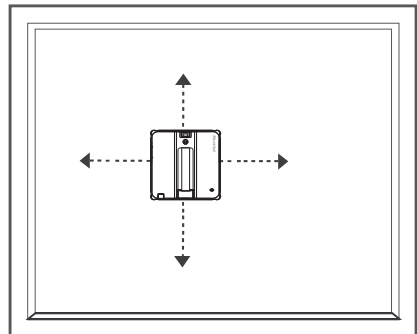

Cleaning the left area in N-Type

Put W120-DP on the glass, press the button on remote or App, it will only clean the left area of the robot in N-Type.

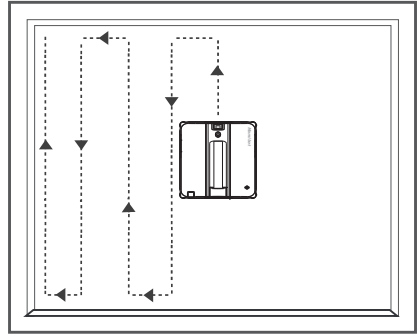

Cleaning the right area in N-Type

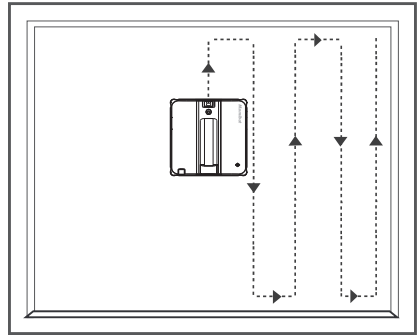

Put W120-DP on the glass, press the button on remote or App, it will only clean the right area of the robot in N-Type.



Upwards/Downwards/Leftwards/Rightwards cleaning

Put W120-DP on the glass, press the button \wedge \vee \langle \rangle on remote or App, the robot will do the upward cleaning, downward cleaning, leftward cleaning, downward cleaning respectively, then stop at the border.

Start / Pause

Put W120-DP on the glass, press the button  on remote or App to start auto cleaning, generally, W120-DP will clean with N shaped path at auto cleaning mode, press the button again to pause the robot. Users can press the button  on the robot to start or pause auto cleaning mode, too.

Language Setting

Press the language button on remote or App to switch between different language voices if the robot is multilingual. Please press the button \wedge \vee on remote to switch the language, then press the button  to confirm it.

Notice:

- Generally, W120-DP will return to the start position after automatic cleaning is finished, it is normal that some times the start position and return position are slightly different.
- The cleaning path is for reference, please subject to the actual products.

Indicator Introduction & Abnormity

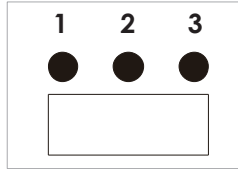

Number		Color	Status		
			On	Blinks	Off
1	Charing indicator	Orange	Charging	/	If the power is off, all the indicators will be off.
		Green	Fully charged	/	
2	Power indicator	White	Powering on	/	
3	Spray indicator	Blue	water spray off	water spray on	
		Red	/	Abnormal	
		Blue + Red	/	Abnormal	

Abnormity	Abnormal Staus
Barometer abnormal	Red blinks 4 times + Beeps 4 times
Gyroscope abnormal	Red blinks 5 times + Beeps 5 times
Microcontroller abnormal	Red blinks 8 times + Beeps 8 times
Edge detection sensor abnormal	Blue is always on + Red blinks
Movement abnormal	Red and blue blinks alternately + long beeps

Installation

Charging

Connecting the adapter, AC cord and the robot properly as below image, then insert the plug into the power outlet:

Charging Indicator:

Solid orange: Charging

Solid green: Fully charged (2 hrs charging).

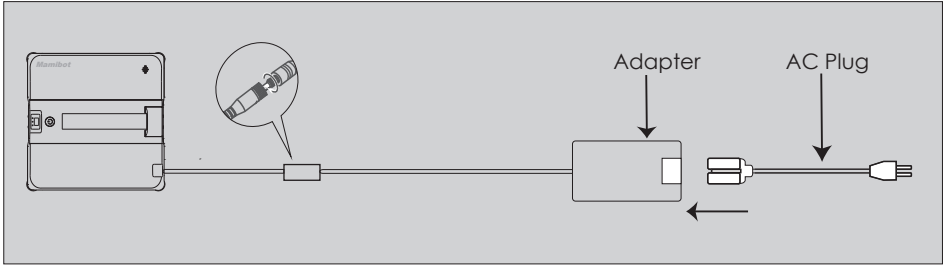

Cleaning cloth installation

- Use the original cleaning cloth, align it with the cleaning plate and attach it to the velcro then flatten the cloth properly.
- The cloth should not cover the wheel belts or edge detection sensors.
- Please do not spray too much water on the cleaning cloth when use to avoid slippery.

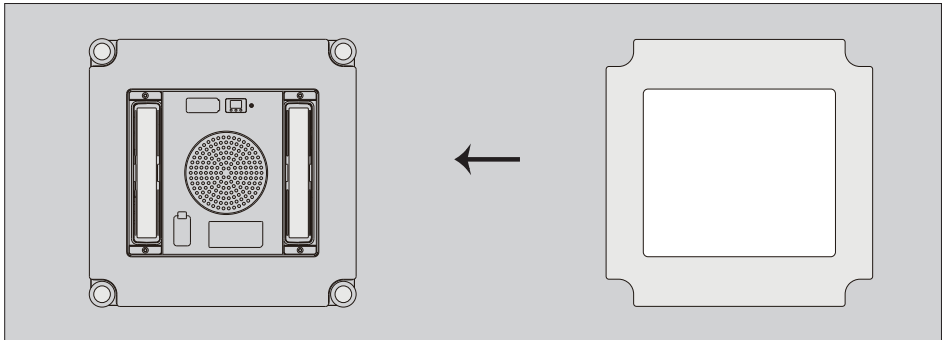

Fill up the water tank

Open the water tank lid, fill up the water tank with clean water before starting it, then seal the lid tightly (do not add pure water for cleaning).

- Do not add dirty water or thick liquids into the water tank.
- Do not add corrosive or flammable liquids into the water tank.

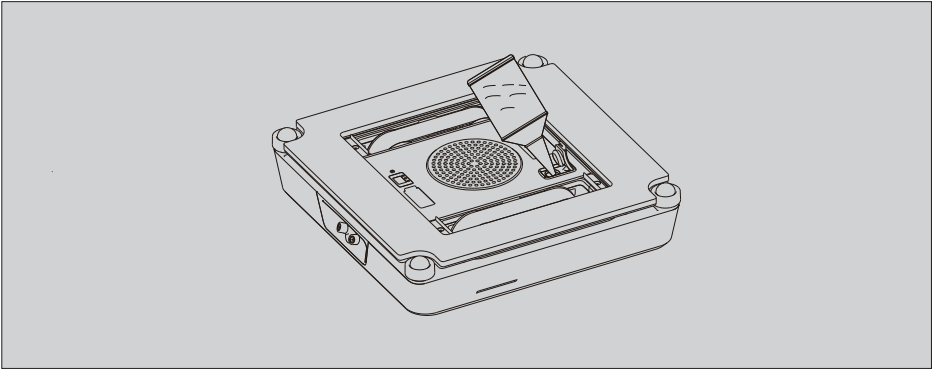

Safety rope fixing

The safety rope must be tied on the indoor fixtures tightly before use. Make sure the length of the safety rope is appropriate for cleaning.

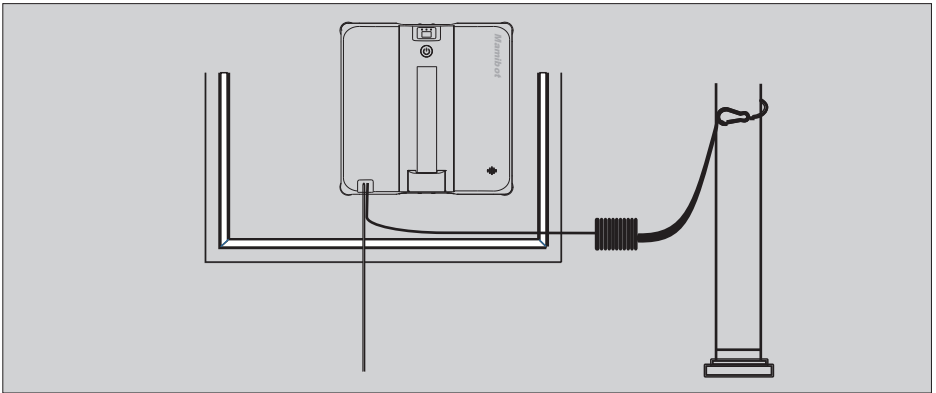

Note:

- 1). Please check the safety rope, make sure the rope is not damaged and the knot is not loose.
- 2). Set danger-warning area downstairs for no-balcony window and door before use.

To use W120-DP

1. Please charge the W120-DP fully, place the cleaning cloth on the cleaning plate, fill up the water tank and fasten the safety rope tightly before use.

2. Plug W120-DP into power outlet, wait for a while until the voice broadcast is finished.

3. Put the W120-DP vertically on a horizontal table (Fig.A) and hold it.
- ① Hold and press the regular spray button (🔊) on remote until water spray out from 2 left nozzles.
 - ② Hold and press the strong spray button (🔊+) on remote until water spray out from 2 right nozzles.
4. hold and press the switch button (🔌) on W120-DP for about 3 seconds to turn W120-DP on, then put it on the window glass firmly.

Note:

Make sure the edge of W120-DP is 8cm or further away from window frames or corners before cleaning (Fig B).

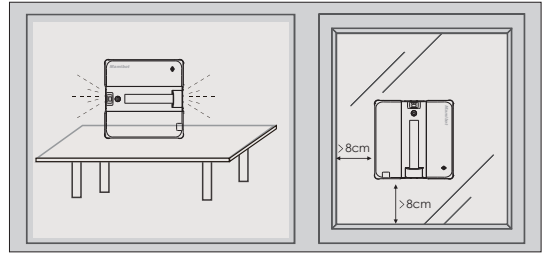

Fig A

Fig B

4. Start:

- 1). Short press the switch button (🔌) on the robot to start auto-cleaning.
- 2). Short press the button (▶) on the remote to start auto-cleaning.
- 3). Users can also press other buttons on the remote or the App (if it has) to operate W120-DP.

5. Pause:

Short press the switch button (🔌) again or short press the button (▶) on the remote again to pause the device.

6. Generally, W120-DP will return to its starting point automatically after cleaning is finished. There is a beep remind when cleaning is finished.

* Use remote to move W120-DP to a reachable location if it doesn't return to the starting point.

7). Hold the hand grip and the safety rope, press switch button (🔌) for 3 seconds, then take the device off from the window.

8). Clean the cloth in time and dry it for future use.

9). Empty the water tank if you are not going to use it for a long time.

10). **UPS:** The UPS is 20-30 mintues, if there is a sudden power outage, please remove the machine in time.

App Use

Note: App version is an optional version, for details, please subject to the local seller.

1. App downloading

Scan the below QR code to download the App of "Smart Life" from App Store (IOS devices) or Google Play (Android devices).



2. Log in/Register "Smart Life" ID.

Enter the App, log in with your "Smart Life" ID directly, or follow the instructions and create a new user ID, then log in and enter App interface.

3. Connect W120-DP to the App.

- 1). Turn on your Bluetooth first.
- 2). Enter the App, tap the " + " icon or " Add Device " as Fig.1.
- 3). Plug the robot into the power outlet, wait until the voice broadcast is finished. **Quick and short press the start button (⏻) on the robot for 3 times to reset the Bluetooth, the buzze will beep 3 times and say reset the network.**
- 4). Then check the App, it will detect and discover the device as Fig.2., add your device, the App will connect your device automatically, click done and finish the connection.

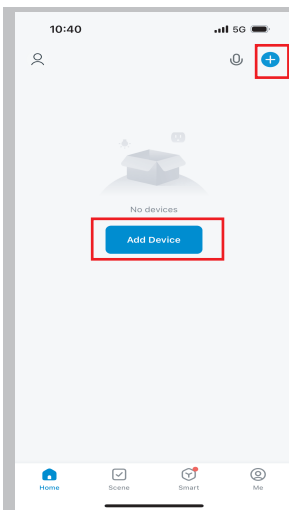

Fig.1

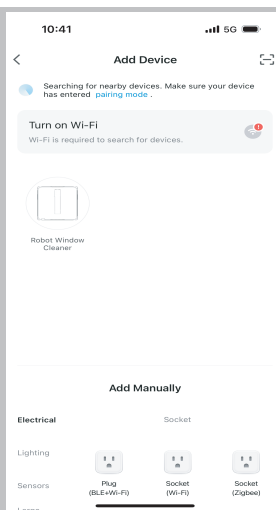

Fig.2

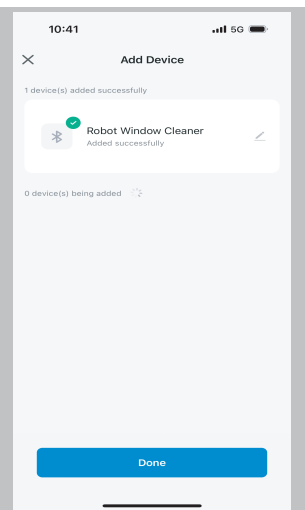

Fig.3

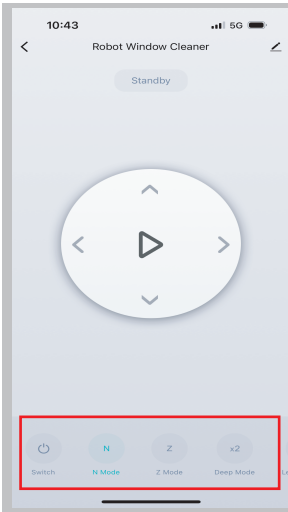

Fig.4

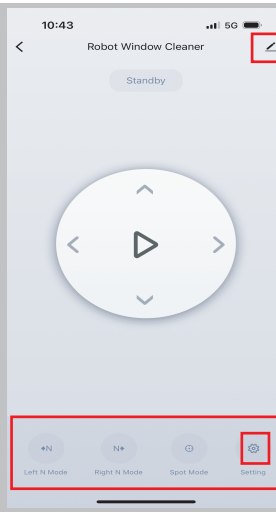

Fig.5

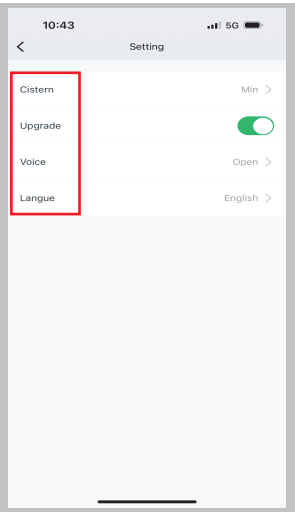

Fig.6

5). Tap the robot icon on the App, enter the interface as Fig.4, swipe right and enter the interface as Fig.5, users can now use the robot by clicking the buttons on the App.

6). Click the setting icon “⚙️” and enter the interface as Fig.6 to set the water spray volume, the voice switch and the language voice.

7). Click the icon “🔍” to check more about the robot as Fig.7.

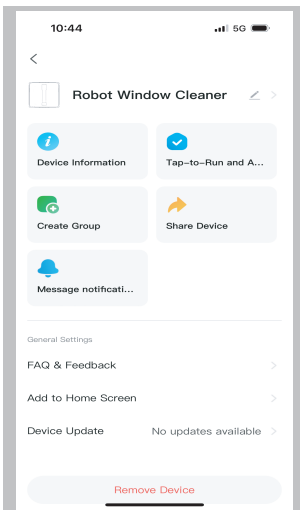

Fig.7

Note:

* If you need to reconnect the App, please unplug the device first, then plug the power outlet again, quick and short press the start button on the robot to reset the network.

* The interface and the operation about the App are for reference due to continuous optimization of the product, please subject to the final actual products.

Maintenance

1. After each cleaning, wash the cleaning cloth and dry them for future use.
2. Wipe the main unit with soft and dry cloth regularly.
3. Clean the wheel belt as below:
 - 1). Plug the W120-DP into the power outlet;
 - 2). Turn over the unit as the picture, press the upwards button “^” on the remote, then the wheel belt will rotate automatically.
 - 3). Wipe off the dirt on the wheel belt with moist paper towel, then press the upwards button “^” again to exit the program.
 - 4). Dry the wheel belt and store it.

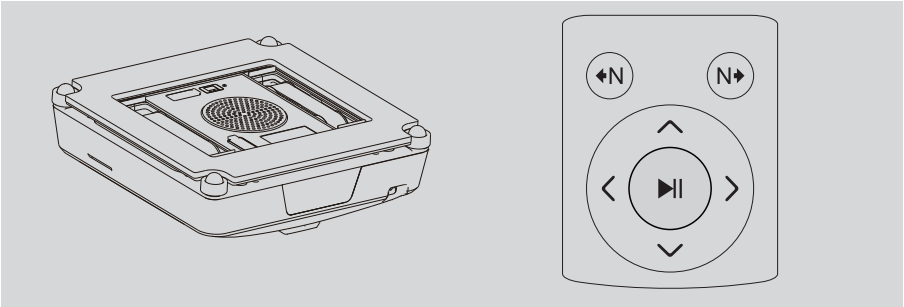

4. Replace the spray nozzle:

The nozzle may be clogged after the robot has been used for a period of time:

- 1). Use a needle nose pliers to remove the nozzles as below picture;
- 2). Put the new nozzles on the original position and fix it.

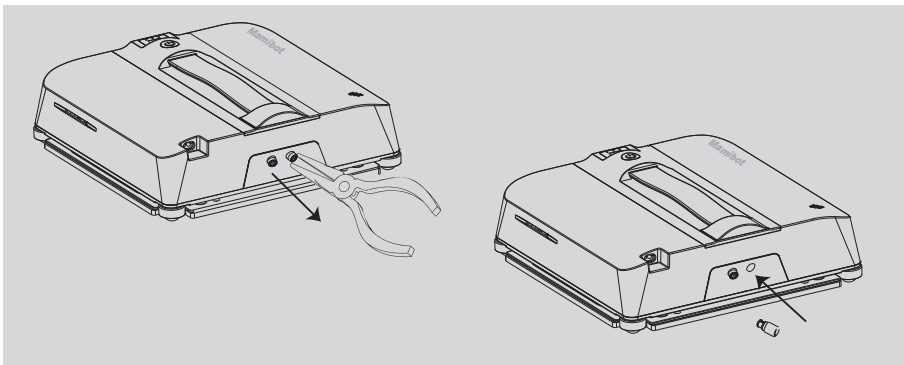

5. Empty the water tank if you do not use it for a long time.
6. Charge W120-DP at least every 3 months if you don't use it for a long time.
7. Cleaning cloth is consumables, replace it according to usage.
8. Store the W120-DP in a cool and dry place away from direct sunlight.

Product Warranty

- The W120-DP has a 1 year limited warranty against original defects in workmanship or material.
- The warranty only applies to the authorized distributors of Mamibot.
- Improper usage or not in accordance with the user manual will void the warranty.
- The application of force majeure will be invalid.
- Normal reductions, such as battery aging, mopping cloth aging are not guaranteed.

Note:

Please keep and provide your invoice and S/N when making a claim.

Questions & Answers

Q1: What types of windows can be cleaned with W120-DP?

A: From floor-to-ceiling windows, small size windows (minimum not less than 60 cm x 40 cm / 23.62 inch x15.75 inch), frameless windows, etc. It can be suitable for most windows.

Q2: Can W120-DP work on seamed glass?

A: It can work if the gap between the parts is less than 5mm, but the gap needs to be sealed, no air leakage, and no height difference.

Q3: Streaks appear after cleaning.

A: If water streaks appear after cleaning, it is recommended to replace a dry and cleaning cloth, then **turn off the water spray** and wipe again.

Q4: W120-DP keeps alerting "insufficient water" even the tank is full.

A: Please confirm if you added purified water, purified water is not applicable for the cleaner, please replace with clean tap water.

Q5: W120-DP may fall or slip on some window frames.

A: Please check if the window frames are irregular-shaped, or if the corners and the frames are uneven, or if the frames are cracked. Please do not use W120-DP on windows with such conditions.

Q6: Can W120-DP work on an inclined surface?

A: We do not recommend consumers to use the machine on an inclined surface.

Q7: W120-DP can not be turned on when hold and press the switch.

A: 1). W120-DP can be turned on only after the power source is plugged in properly.

2). If the battery capacity is low, W120-DP may not be turned on at first, please charge it. We strongly recommend you charge the cleaner fully at initial use.

Q7: How to clean the window glass if the glass is heavy dirty?

A: 1). If there is sand or hard debris on the glass, please clean it manually first to avoid scratching the glass when use. Then put W120-DP on the glass and start to clean, please **switch off the water spray at the first cleaning**.
2). After the first cleaning finished, please replace a piece of cleaning mop, and start cleaning **at second time (make sure the water spray is turned on)**.
3). After the second time cleaning finished, please replace a piece of dry cleaning mop, and start cleaning again, **please turn off the water spray at the third cleaning time**.

Q8: How to clean the window glass if the glass is not too dirty?

A: Please follow the two steps:

1). Put the dry cleaning mop on W120-DP, start it, make sure the water spray is turned on.
2). After the first cleaning finished, please replace a piece of cleaning mop and start, please turn off the water spray at the second cleaning time.

Q9: W120-DP does not stop after the cleaning work is finished.

A: Please press the button (▶) on the remote or the App to stop W120-DP manually if W120-DP finished the cleaning work.

Q10: W120-DP did not finish the cleaning work due to some reasons.

A: Put the device on the point that it stopped, press the button < or > on remote to continue cleaning work.

Q11: Can users spray some water manually on the glass before use?

A: It is not recommended to spray water on the glass before use to prevent the device from slipping.

Q12: Can users add cleaning agent into the water tank for use?

A: Users can add the cleaning agent that is **no thick, no foam and diluted** into the tank. Spray nozzles may be blocked if the dilution ratio is not controlled properly.

Q13: How to remove W20-DP if there is a sudden power outage?



A: 1). Hold the safety rope tightly and keep your hand as close to the device as possible.
2) Make sure that the safety rope parallel to the working surface, then slowly pull the device in front of you and remove it.

Q14: W120-DP can not connect to the smart App (App version).

A: 1). Unplug the power supply first.

- 2). Follow the step of Page 14, 3.3 to reset the bluetooth.
- 3). Follow the guideline of App connection and connect to the smart App.

Troubleshooting

Malfunction	Possible Causes	Solutions
W120-DP gets slippery or works in irregular pattern.	<ol style="list-style-type: none"> 1. Glass is too dirty or too wet. 2. Cleaning cloth is too dirty or too wet. 3. Glass is too dry. 	<ol style="list-style-type: none"> 1. Use a clean cloth. 2. Cleaning the driving wheels. 3. Do not use it in moist or rainy days. 4. Spray some water on the cloth first if the glass is too dry.
Remote does not work.	<ol style="list-style-type: none"> 1. No battery inside or battery has low power in remote. 2. Remote is broken. 	<ol style="list-style-type: none"> 1. Replace the battery. 2. Replace the remote with new one.
W120-DP got stuck on glass frames.	Edge detection misjudgement.	Stop W120-DP first, pull the robot lightly to reachable location, then try again.
Squeaky sound when use.	Glass is too dry or edge detection sensors are too dirty.	<ol style="list-style-type: none"> 1. Spray a little water on the cleaning cloth before use. 2. Clean the edge detection sensors and use again.
W120-DP does not return to the starting point after cleaning.	The friction index of glass is different.	Use remote control to operate the device so as to return to reachable location.
W120-DP does not spray when use at first time or after refill the water tank.	<ol style="list-style-type: none"> 1. The water pipe is short of water at initial use. 2. The water pipeline is blocked. 3. Pure water was added into the tank. 	<ol style="list-style-type: none"> 1. Plug W120-DP, press the buttons  or  on remote to fill the water pipe until the nozzle sprays water. 2. Do not add pure water into the tank for cleaning. 3. Use the unclogging needle kit to unclog the spray nozzle (Fig.8). 4. Replace the spray nozzle.
Movement abnormal	<ol style="list-style-type: none"> 1. Cleaning cloth is not installed properly. 2. The wheels are stuck by something. 	<ol style="list-style-type: none"> 1. Reinstall the cloth properly. 2. Check and clean the wheels.

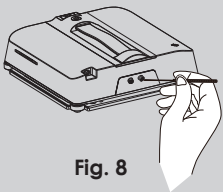

Fig. 8

* Re-connect the power outlet and restart the device if the problems can not be solved by the mentioned methods.

Or please contact the local seller or email info@mamibot.com for further services.

Correct Disposal & Conformity



The symbol on the product or on its package indicates that this product may not be treated as household waste. Instead, it should be taken to the appropriate collection point for the recycling of electrical and electronic equipment. By ensuring this product is disposed of correctly, you will help prevent potential negative consequences for the environment and human health which could otherwise be caused by inappropriate waste handling of this product. For more detailed information about recycling of this product, please contact your local council, your household waste disposal service or the shop where you purchased the product.



The product was tested and found to be in compliance with: Directive 2014/53/EU, and 2014/35/EU, RoHS 2.0 Directive (EU) 2015/863.

FCC Statement:

This device complies with Part 15 of the FCC Rules. Operation is subject to following two conditions:

(1) This device may not cause harmful interference; (2) This device must accept any interference received, including interference that may cause undesired operation.

Warning: Changes or modifications not expressly approved by the party responsible for compliance could void the user's authority to operate the equipment.

We reserve the right to changes in text, design, and technical specifications which are subject to change without prior notice.

Manufacturer:

Mamibot Manufacturing (Shanghai) Co.,Ltd.
North of 21st FL, No.1 Building, LN1040, Caoyang Rd, Shanghai, P.R.C.

Supervised by

Mamibot Manufacturing USA Inc.
One Commerce Center, 1201 Orange St, Wilmington, DE 19899 USA
Tel: 001 302-428-9888 info@mamibot.com www.mamibot.com

